



United Technologies

## SELECTION      P R O D U I T



- Multi Tiering: Entry and premium efficiency
- Available for cooling (30XW) or heating (30XWH) operation
- Wide operating envelope: down to -12°C chilled liquid temperature, up to +63°C hot water temperature
- Compactness: less than 1.2 m width up to 1600 kW

Water-Cooled Screw Chillers  
Water-sourced screw heat pumps

30XW/30XW-P  
30XWH/30XWHP



CARRIER participates in the ECP programme for LCP/HP  
Check ongoing validity of certificate:  
[www.eurovent-certification.com](http://www.eurovent-certification.com)  Certiflash  
[www.certiflash.com](http://www.certiflash.com)

**AQUAFORCE**

# 30XW- 30XWH

**Nominal cooling capacity 273-1756 kW**

**Nominal heating capacity 317-1989 kW**

## Introduction

The 30XW liquid chillers are the premium solution for industrial and commercial applications where installers, consultants and building owners require optimal performances and maximum quality.

The 30XW liquid chillers are designed to meet current and future requirements in terms of energy efficiency, flexibility of use and compactness. They use the most reliable technologies available today:

- Twin-rotor screw compressors with a variable capacity valve
- Refrigerant R134a
- Touch Pilot control system
- Flooded heat exchangers that are mechanically cleanable

To meet to all environmental and economic requirements, the 30XW is available in two efficiency classes:

- Entry-level efficiency 30XW units that offer an optimised balance of technical and economical aspects,
- Premium-efficiency 30XW-P units that offer unequalled energy efficiency to satisfy the most stringent demands of building owners wanting to reduce operating costs to the minimum.

The 30XW Aquaforce range is also split into two versions:

- 30XW for air conditioning and refrigeration applications
- 30XWH for heating applications

As standard, the unit can provide an evaporator leaving temperature down to 3,3°C (-12°C optional), and when operating as a heat pump, it can deliver up to 50°C (63°C optional) on the condenser side.

## Customer Benefits

### Low energy consumption

- Eurovent energy efficiency class “A”
- EER of up to 5,9 and ESEER up to 6,8
- GROSS-EER up to 6,1 and GROSS-ESEER up to 7,9
- The high energy efficiency is reached through:
  - Twin-rotor screw compressor equipped with a high-efficiency motor and a variable capacity valve that permits exact matching of the cooling capacity to the load.
  - Flooded multi-pipe heat exchangers for increased heat exchange efficiency.
  - Electronic expansion device permitting operation at a lower condensing pressure and improved utilisation of the evaporator heat exchange surface.
  - Economizer system with electronic expansion device for increased cooling capacity (30XW-P).

### Low operating sound levels

- Standard unit features include:
  - Silencers on the compressors discharge line.
  - Silencers on the economiser return line.
  - Acoustic insulation on the components that are most subjected to radiated noise.
  - Option 257 further reduces the global unit sound level.

### Easy and fast installation

- Compact design
  - The 30XW units are designed to offer the most compact dimensions on the market.
  - With a width of approximately 1 m up to 1600 kW the units can pass through standard door openings and only require minimum floor space in the plant room.

### Compact, accessible unit - side view - sizes up to 1600 KW

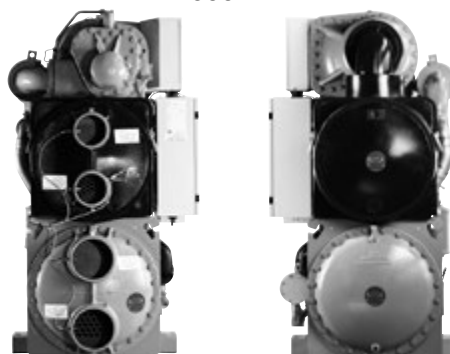

- Simplified electrical connections
  - Main disconnect switch with high trip capacity
  - Transformer to supply the integrated control circuit (400/24 V)
- Simplified hydronic connections
  - Victaulic connections on the evaporator and condenser
  - Practical reference marks for entering and leaving water connections
  - Possibility to reverse the heat exchanger water inlet and outlet at the factory
  - Possibility to modify the number of heat exchanger passes
- Fast commissioning
  - Systematic factory operation test before shipment
  - Quick-test function for step-by-step verification of the instruments, expansion devices and compressors.

## Environmental care

- R-134a refrigerant
  - HFC refrigerant with zero ozone depletion potential
- Leak-tight refrigerant circuit
  - Reduction of leaks as no capillary tubes and flare connections are used
  - Verification of pressure transducers and temperature sensors without transferring refrigerant charge
  - Discharge line shut-off valve and liquid line service valve for simplified maintenance.

## High reliability and easy servicing

- The 30XW units offer increased global performance as well as Carrier's acclaimed product quality and reliability.
- Major components are selected and tested to minimize failures possibility, as well as many design choices have been taken in this perspective.
- Screw compressors
  - Industrial-type screw compressors with oversized bearings and motor cooled by suction gas.
  - All compressor components are easily accessible on site minimising down-time.
- Refrigerant circuit
  - Two independent refrigerant circuits (from 1000 kW upwards); the second one automatically takes over, if the first one develops a fault, maintaining partial cooling under all circumstances.
- Evaporator
  - Electronic paddle-free flow switch. Auto-setting according to cooler size and fluid type.
- Auto-adaptive control
  - Control algorithm prevents excessive compressor cycling (Carrier patent)
  - Automatic compressor unloading in case of abnormally high condensing pressure.
- Exceptional endurance tests
  - Partnerships with specialised laboratories and use of limit simulation tools (finite element calculation) for the design of critical components.
  - Transport simulation test in the laboratory on a vibrating table and then on an endurance circuit (based on a military standard).

## Technical insights

### Touch Pilot Control

#### Touch Pilot control, 5" user interface



- New innovative smart control features:
  - An intuitive and user-friendly, coloured, 5" interface (7" optional)
  - Direct access to the unit's technical drawings and the main service documents
  - Screen-shots with concise and clear information in local languages
  - Complete menu, customised for different users (end user, service personnel and Carrier-factory technicians)
  - Easy access to the controller box with inclined touch screen mounting to ensure legibility under any lighting conditions
  - Safe operation and unit setting: password protection ensures that unauthorised people cannot modify any advanced parameters
  - Simple and "smart" intelligence uses data collection from the constant monitoring of all machine parameters to optimise unit operation.
- Energy management:
  - Internal time schedule clock controls chiller on/off times and operation at a second set-point
  - The DCT (Data Collection Tool) records the alarms history to simplify and facilitate service operations.

### Remote Management (Standard)

- Units with Touch Pilot control can be easily accessed from the internet, using a PC with an Ethernet connection. This makes remote control quick and easy and offers significant advantages for service operations.
- The 30XW also communicates with other building management systems via optional communication gateways.
- The 30XW is equipped with an RS485 serial port that offers multiple remote control, monitoring and diagnostic possibilities. Carrier offers a vast choice of control products, specially designed to control, manage and supervise the operation of an air conditioning system. Please consult your Carrier representative for more information.

- The following commands/visualisations are possible from remote connection:
  - Condenser pumps control: a digital input allows verification of condenser water flow (the flow switch must be supplied by the installer)
  - Start/stop of the machine
  - Dual set-point management: through a dedicated contact is possible to activate a second set-point (example: unoccupied mode)
  - Demand limit setting: to limit the maximum chiller capacity to a predefined value
  - Operation visualization: indication if the unit is operating or if it's in stand-by (no cooling load)
  - alarm visualization.

### Remote management (EMM option)

- The Energy Management Module offers extended remote control possibilities:
  - Room temperature: permits set-point reset based on the building indoor air temperature (with Carrier thermostat)
  - Set point reset: ensures reset of the cooling set-point based on a 4-20 mA or 0-10 V signal
  - Demand limit: permits limitation of the maximum chiller power or current based on a 0-10 V signal
  - Demand limit 1 and 2: closing of these contacts limits the maximum chiller power or current to two predefined values
  - User safety: this contact can be used for any customer safety loop; opening of the contact generates a specific alarm
  - Ice storage end: when ice storage has finished, this input permits return to the second set-point (unoccupied mode)
  - Time schedule override: closing of this contact cancels the time schedule effects
  - Out of service: this signal indicates that the chiller is completely out of service
  - Chiller capacity: this analogue output (0-10 V) gives an immediate indication of the chiller capacity
  - Alert indication: this volt-free contact indicates the necessity to carry out a maintenance operation or the presence of a minor fault.

### 06T screw compressor

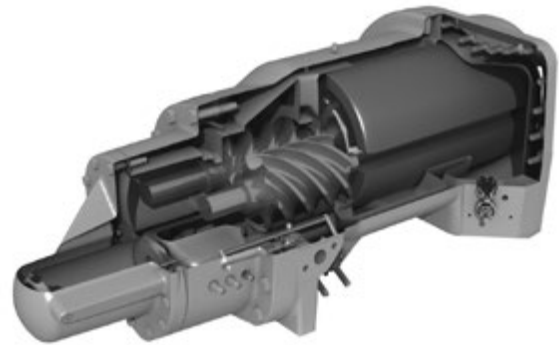

The new generation of the Carrier 06T screw compressors benefits from Carrier's long experience in the development of twin-rotor screw compressors. The compressor is equipped with bearings with oversized rollers, oil pressure lubricated for reliable and durable operation, even at maximum load.

A variable control valve controlled by the oil pressure permits infinitely variable cooling capacity. This system allows optimal adjustment of the compressor cooling capacity and ensures exceptionally high stability of the chilled water leaving temperature.

Among the other advantages: if a fault occurs e.g. if the condenser is fouled or at very high water temperature, the compressor does not switch off, but continues operation with a reduced capacity (unloaded mode).

The silencer in the discharge line considerably reduces discharge gas pulsations for much quieter operation.

The condenser includes an oil separator that minimises the amount of oil in circulation in the refrigerant circuit and re-directs it to the compressor function.

# Options

Options	No.	Description	Advantages	Use for 30XW range
Medium-temperature brine solution	5	Implementation of new algorithms of control and evaporator redesign to allow chilled brine solution production down to -6°C when ethylene glycol is used (-3°C with propylene glycol)	Covers specific applications such as ice storage and industrial processes	Only sizes 512/562/1012/1154
Low-temperature brine solution	6	Implementation of new algorithms of control and evaporator redesign to allow chilled brine solution production down to -12°C when ethylene glycol is used (-8°C with propylene glycol)	Covers specific applications such as ice storage and industrial processes	Only sizes 512/562/1012/1154
Light-brine solution, down to -3°C	8	Implementation of new algorithms of control to allow chilled brine solution production down to -3°C when ethylene glycol is used (0°C with propylene glycol)	Matches with most application requirements for ground-sourced heat pumps and fits with many industrial processes requirements	254-1762
Unit supplied in two assembled parts	51	The unit is equipped with flanges that allow disassembly of the unit on site	Facilitates installation in plant rooms with limited access	Only sizes 1612/1652/1702/1762
Master/slave operation	58	Unit equipped with supplementary water outlet temperature sensor kit to be field-installed allowing master/slave operation of two units connected in parallel	Optimised operation of two chillers connected in parallel with operating time equalisation	254-1762
Single power connection point	81	Unit power connection via one main supply connection	Quick and easy installation	1002-1762
No disconnect switch, but short circuit protection	82A	Unit without disconnect switch, but with short-circuit protection device	Permits an external electrical disconnect system for the unit (field-supplied), while ensuring unit short circuit protection	254-1762
Evaporator pump electrical power / control circuit	84	Unit equipped with an electrical power and control circuit for one pump evaporator side	Quick and easy installation: the control of fixed speed pumps is embedded in the unit control	254-1252, 1314
Evaporator dual pumps electrical power / control circuit	84D	Unit equipped with an electrical power and control circuit for two pumps evaporator side	Quick and easy installation: the control of fixed speed pumps is embedded in the unit control	254-1252, 1314
Condenser pump electrical power / control circuit	84R	Unit equipped with an electrical power and control circuit for one pump condenser side	Quick and easy installation: the control of fixed speed pumps is embedded in the unit control	254-1252, 1314
Condenser insulation	86	Thermal condenser insulation	Minimizes thermal dispersions condenser side (key option for heat pump or heat recovery applications) and allows compliancy with special installation criteria (hot parts insulated)	254-1762
Service valve set	92	Liquid line valve (evaporator inlet) and compressor suction line valve	Allow isolation of various refrigerant circuit components for simplified service and maintenance	254-1762
Evaporator with one pass	100C	Evaporator with one pass on the water side. Evaporator inlet and outlet on opposite sides.	Easy to install, depending on site. Reduced pressure drops	254-1762
Condenser with one pass	102C	Condenser with one pass on the water side. Condenser inlet and outlet on opposite sides.	Easy to install, depending on site. Reduced pressure drops	254-1762
21 bar evaporator	104	Reinforced evaporator for extension of the maximum water-side service pressure to 21 bar (standard 10 bar)	Covers applications with a high water column evaporator side (typically high buildings)	254-1762
21 bar condenser	104A	Reinforced condenser for extension of the maximum water-side service pressure to 21 bar (standard 10 bar)	Covers applications with a high water column condenser side (typically high buildings)	254-1762
Reversed evaporator water connections	107	Evaporator with reversed water inlet/outlet	Easy installation on sites with specific requirements	254-1762
Reversed condenser water connections	107A	Condenser with reversed water inlet/outlet	Easy installation on sites with specific requirements	254-1762
JBus gateway	148B	Two-directional communication board complying with JBus protocol	Connects the unit by communication bus to a building management system	254-1762
LON gateway	148D	Two-directional communication board complying with Lon Talk protocol	Connects the unit by communication bus to a building management system	254-1762
Bacnet over IP gateway	149	Two-directional high-speed communication using BACnet protocol over Ethernet network (IP)	Easy and high-speed connection by ethernet line to a building management system. Allows access to multiple unit parameters	254-1762
High condensing temperature	150	Optimized compressor for operation at high condensing temperature	Increased condenser leaving water temperature up to 63°C. Allows applications with high condensing temperature (heat pumps, installations with not generously sized dry-coolers or more generally, installations with dry-coolers in hot climate). NOTE: to ensure control of the condenser leaving water temperature, this option must be fitted with 30XWH units.	254-1762
Condensing temperature limitation	150B	Limitation of the maximum condenser leaving water temperature to 45°C	Reduced maximum power input and current absorption: power cables and protection elements can therefore be downsized	254-1762
Control for low condensing temperature systems	152	Output signal (0-10 V) to control the condenser water inlet valve	Simple installation: for applications with cold water at condenser inlet (ex. ground-source, groundwater-source, superficial water-source applications) the signal permits to control a 2 or 3-way valve to maintain condenser water temperature (and so condensing pressure) at acceptable values	254-1762
Energy Management Module EMM	156	Control board with additional inputs/outputs. See Energy Management Module option chapter	Extended remote control capabilities (Set-point reset, ice storage end, demand limits, boiler on/off command...)	254-1762
Touch Pilot control, 7" user interface	158A	Touch Pilot control supplied with a 7 inch colour touch screen user interface	Enhanced ease of use	254-1762
Leak detection	159	0-10 V signal to report any refrigerant leakage in the unit directly on the controller (the leak detector itself must be supplied by the customer)	Immediate customer notification of refrigerant losses to the atmosphere, allowing timely corrective actions	254-1762
Compliance with Swiss regulations	197	Additional tests on the water heat exchangers: supply (additional of PED documents) supplementary certificates and test certifications	Conformance with Swiss regulations	254-1762
Compliance with Australian regulations	200	Unit approved to Australian code	Conformance with Australian regulations	254-1762
Low noise level	257	Evaporator sound insulation	3 dB(A) quieter than standard unit	254-1762
Welded evaporator water connection kit	266	Victaulic piping connections with welded joints	Easy installation	254-1762
Welded condenser water connection kit	267	Victaulic piping connections with welded joints	Easy installation	254-1762
Flanged evaporator water connection kit	268	Victaulic piping connections with flanged joints	Easy installation	254-1762
Flanged condenser water connection kit	269	Victaulic piping connections with flanged joints	Easy installation	254-1762
Thermal compressor insulation	271	The compressor is covered with a thermal insulation layer	Prevents air humidity to condensate on the compressor surface	254-1762
230V electrical plug	284	230V AC power supply source provided with plug socket and transformer (180 VA, 0,8 Amps)	Permits connection of a laptop or an electrical device during unit commissioning or servicing	254-1762
Carrier Connect link (BSS regions only)	298	3G router board NOTE 1: require option 149 NOTE 2: when more than one machine is installed on site, only one of them shall be equipped with option 298 while all of them must be equipped with option 149 NOTE 3: if a CARRIER-PSM is on site, option 298 shall be integrated in the PSM while option 149 is still mandatory for each single unit.	Enabler for Carrier Connect service offer	254-1762

# Physical data, standard units

## High-efficiency units

30XW-P/30XWHP		512	562	712	812	862	1012	1162	1314	1464	1612	1762
<b>Air conditioning application as per EN14511-3:2013† - standard unit</b>												
Condition 1												
Nominal cooling capacity	kW	509	577	737	786	861	1039	1157	1323	1452	1626	1756
ESEER	kW/kW	6.09	6.14	6.41	6.24	6.17	6.74	6.83	6.65	6.36	6.80	6.60
EER	kW/kW	5.71	5.64	5.83	5.62	5.65	5.73	5.78	5.80	5.58	5.87	5.79
Eurovent class cooling	-	A	A	A	A	A	A	A	A	A	-	-
<b>Air conditioning application †† - standard unit</b>												
Condition 1												
Nominal cooling capacity	kW	510	578	739	788	863	1042	1161	1329	1459	1632	1764
ESEER	kW/kW	6.61	6.77	6.94	6.83	6.84	7.47	7.89	7.70	7.48	7.65	7.52
EER	kW/kW	5.94	5.89	6.04	5.85	5.92	5.95	6.07	6.13	5.93	6.13	6.08
<b>Heating application as per EN14511-3:2013† - standard unit</b>												
Condition 2												
Nominal heating capacity	kW	583	662	842	904	982	1191	1320	1509	1663	1846	1989
COP	kW/kW	4.91	4.84	4.97	4.80	4.85	4.90	4.86	4.89	4.71	4.89	4.87
Eurovent class heating	-	A	A	A	A	A	A	A	-	-	-	-
<b>Heating application ††</b>												
Condition 2												
Nominal heating capacity	kW	581	660	840	901	978	1188	1316	1503	1657	1841	1983
COP	kW/kW	5.12	5.07	5.17	5.01	5.10	5.14	5.19	5.23	5.07	5.18	5.19
<b>Sound levels - standard unit</b>												
Sound power level*	dB(A)	99	99	99	99	99	102	102	102	102	102	102
Sound pressure level at 1 m**	dB(A)	82	82	81	81	81	83	83	83	83	83	83
<b>Sound levels - standard unit + option 257***</b>												
Sound power level*	dB(A)	96	96	96	96	96	99	99	99	99	99	99
Sound pressure level at 1 m**	dB(A)	78	78	78	78	78	80	80	80	80	80	80
<b>Dimensions - standard unit</b>												
Length	mm	3059	3059	3290	3290	3290	4730	4730	4730	4730	4832	4832
Width	mm	936	936	1069	1069	1069	1039	1039	1162	1162	2129	2129
Height	mm	1743	1743	1950	1950	1950	1997	1997	2051	2051	1562	1562
Operating weight****	kg	2981	3020	3912	3947	3965	6872	6950	7542	7752	10910	10946
<b>Compressors</b>												
Semi-hermetic 06T screw compressors, 50 r/s												
Circuit A	-	1	1	1	1	1	1	1	1	1	1	1
Circuit B	-	-	-	-	-	-	1	1	1	1	1	1
<b>Refrigerant**** - standard unit</b>												
R-134a												
Circuit A	kg	130	130	180	175	170	120	120	130	130	240	250
Circuit B	kg	-	-	-	-	-	120	120	150	130	240	250
<b>Global Warming Potential (GWP)</b>												
Tonnes of equivalent CO <sub>2</sub> of greatest circuit	tonnes	186	186	257	250	243	172	172	215	186	343	358
<b>Capacity control</b>												
Touch Pilot, electronic expansion valves (EXV)												
Minimum capacity	%	15	15	15	15	15	10	10	10	10	10	10
<b>Evaporator</b>												
Multi-pipe flooded type												
Water volume	l	101	101	154	154	154	293	293	321	321	473	473
Water connections (Victaulic)	in	6	6	8	8	8	8	8	8	8	10	10
Drain and vent connections (NPT)	in	3/8	3/8	3/8	3/8	3/8	3/8	3/8	3/8	3/8	3/8	3/8
Max. water-side operating pressure	kPa	1000	1000	1000	1000	1000	1000	1000	1000	1000	1000	1000
<b>Condenser</b>												
Multi-pipe flooded type												
Water volume	l	103	103	148	148	148	316	316	340	340	623	623
Water connections (Victaulic)	in	6	6	8	8	8	8	8	8	8	10	10
Drain and vent connections (NPT)	in	3/8	3/8	3/8	3/8	3/8	3/8	3/8	3/8	3/8	3/8	3/8
Max. water-side operating pressure	kPa	1000	1000	1000	1000	1000	1000	1000	1000	1000	1000	1000

† Eurovent-certified performances in accordance with standard EN14511-3:2013.

†† Gross performances, not in accordance with EN14511-3:2013. These performances do not take into account the correction for the proportional heating capacity and power input generated by the water pump to overcome the internal pressure drop in the heat exchanger.

Condition 1 : Cooling mode conditions, evaporator water entering/leaving temperature 12°C/7°C, condenser water entering/leaving temperature 30°C/35°C, evaporator fouling factor 0 m<sup>2</sup>.K/W.

Condition 2: Cooling mode conditions, condenser water entering/leaving temperature 40°C/45°C, evaporator water entering/leaving temperature 10°C/7°C, evaporator fouling factor 0 m<sup>2</sup>.K/W.

\* In dB ref=10<sup>-12</sup> W, (A) weighting. Declared dualnumber noise emission values in accordance with ISO 4871 (with an associated uncertainty of +/-3dB(A)). Measured in accordance with ISO 9614-1 and certified by Eurovent.

\*\* In dB ref 20µPa, (A) weighting. Declared dualnumber noise emission values in accordance with ISO 4871 (with an associated uncertainty of +/-3dB(A)). For information, calculated from the sound power level Lw(A).

\*\*\* Option 257 = Low noise level.

\*\*\*\* Weight shown is guideline only. Please refer to the unit nameplate.



Eurovent certified values

# Operating limits and operating ranges

Standard 30XW-- and 30XW-P units	Minimum	Maximum
<b>Evaporator</b>		
Entering temperature at start-up	-	35.0°C
Leaving temperature during operation	3.3°C*	20.0°C
Entering/leaving temperature difference at full load	2.8 K	11.1 K
<b>Condenser</b>		
Entering temperature at start-up	13.0°C**	-
Leaving temperature during operation	19.0°C**	50.0°C***
Entering/leaving temperature difference at full load	2.8 K	11.1 K

- \* For low-temperature applications, where the leaving water temperature is below 3.3°C, a frost protection solution must be used. Please refer to option 5 and option 6.
- \*\* For lower condenser temperatures, a water flow control valve must be used at the condenser (two or three-way valve). Please refer to option 152 to ensure the correct condensing temperature.
- \*\*\* Please refer to option 150 for applications with a high condenser leaving temperature (up to 63°C).

Units with option 150	Minimum	Maximum
<b>30XW--/30XWH-/30XW-P/30XWHP</b>		
<b>Evaporator</b>		
Entering temperature at start-up	-	35.0°C
Leaving temperature during operation	3.3°C*	15.0°C
Entering/leaving temperature difference at full load	2.8 K	11.1 K
<b>Condenser</b>		
Entering temperature at start-up	13.0°C**	-
Leaving temperature during operation	23.0°C**	63.0°C
Entering/leaving temperature difference at full load	2.8 K	11.1 K

- \* For low-temperature applications, where the leaving water temperature is below 3.3°C, a frost protection solution must be used. Please refer to option 5 and option 6.
- \*\* For lower condenser temperatures, a water flow control valve must be used at the condenser (two or three-way valve). Please refer to option 152 to ensure the correct condensing temperature.

Units with options 5 and 6	Minimum	Maximum
<b>30XW-- (1154)/30XW-P (512-562-1012)</b>		
<b>Evaporator</b>		
Entering temperature at start-up	-	35.0°C
Leaving temperature during operation*		
EG 5 Option 5 with ethylene glycol	-6°C	15.0°C
PG 5 Option 5 with propylene glycol	-3°C	15.0°C
EG 6 Option 6 with ethylene glycol	-12°C	15.0°C
PG 6 Option 6 with propylene glycol	-8°C	15.0°C
Entering/leaving temp. difference at full load	2.8 K	11.1 K***
<b>Condenser</b>		
Entering temperature at start-up	13.0°C**	-
Leaving temperature during operation	19.0/23.0°C**	55.0/63.0°C****
Entering/leaving temp. difference at full load	2.8 K	11.1 K

- \* The operating range with evaporator leaving temperatures above 3°C is permitted, but the performances are not optimised.
- \*\* For lower condenser temperatures, a water flow control valve must be installed at the condenser (two-way or three-way). Please refer to option 152 to ensure the correct condensing temperature.
- \*\*\* Please refer to chapter 10.5 of the installation manual for the minimum recommended evaporator glycol flow rate.
- \*\*\*\* Depends on the conditions at the evaporator and the load conditions.

## Standard units

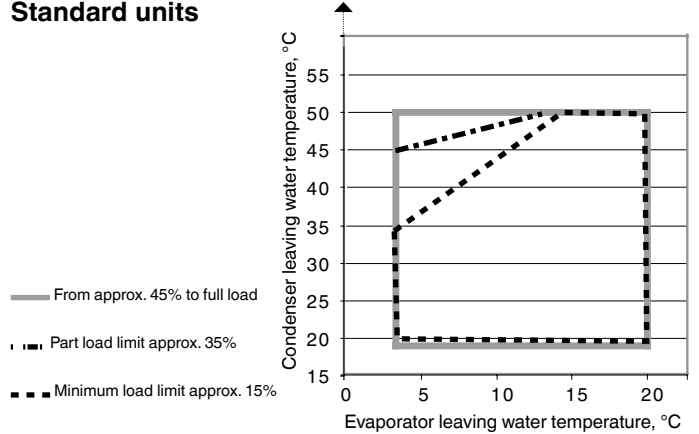

## Option 150

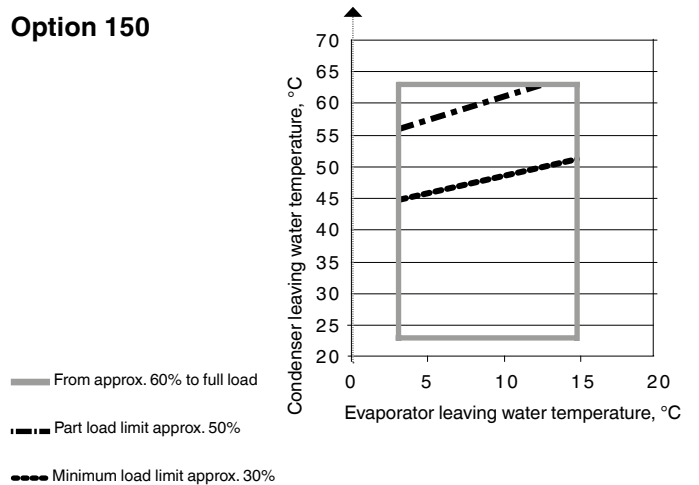

## Options 5 and 6

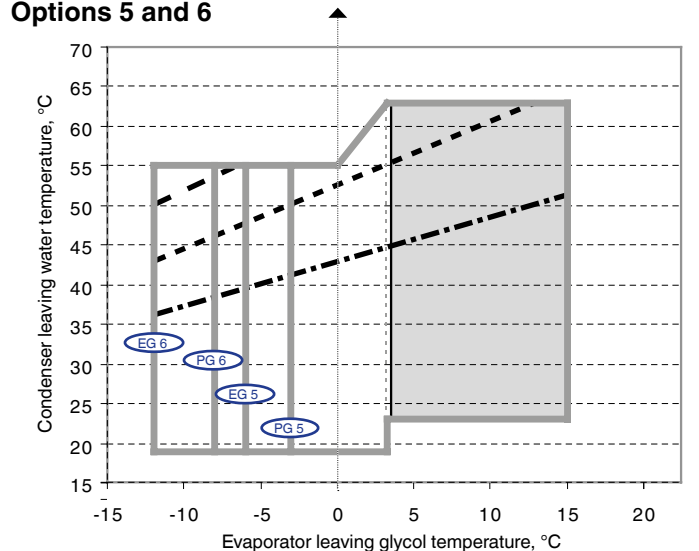

**NOTES:** Ambient temperatures: During storage and transport of the 30XW units (including by container) the minimum and maximum permissible temperatures are -20°C and 72°C (and 65°C for option 200).

For more precise details refer to the unit selection program.

# Evaporator pressure drop curves

**Units with two evaporator passes (standard):**  
**30XW--/30XWH-/30XW-P/30XWHP**

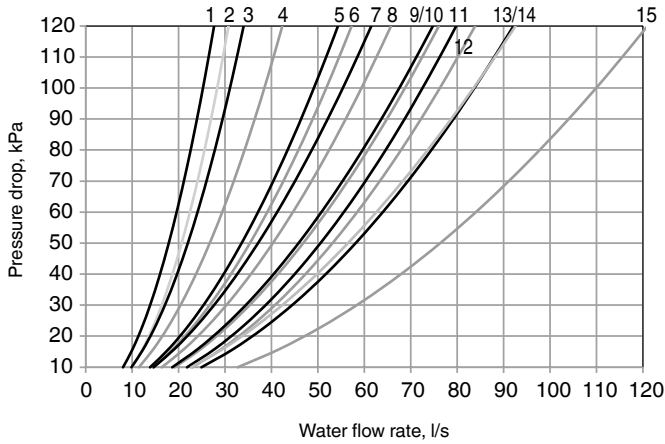

**Legend**

- 1. 254
- 2. 304
- 3. 354
- 4. 402, 452, 552, 602
- 5. 512, 562
- 6. 652, 702, 802
- 7. 852
- 8. 1002, 1052
- 9. 1154
- 10. 712, 812, 862
- 11. 1012, 1162
- 12. 1252, 1352, 1452, 1552
- 13. 1314, 1464
- 14. 1652, 1702
- 15. 1612, 1762

**Units with one evaporator pass (option 100C):**  
**30XW--/30XWH-/30XW-P/30XWHP**

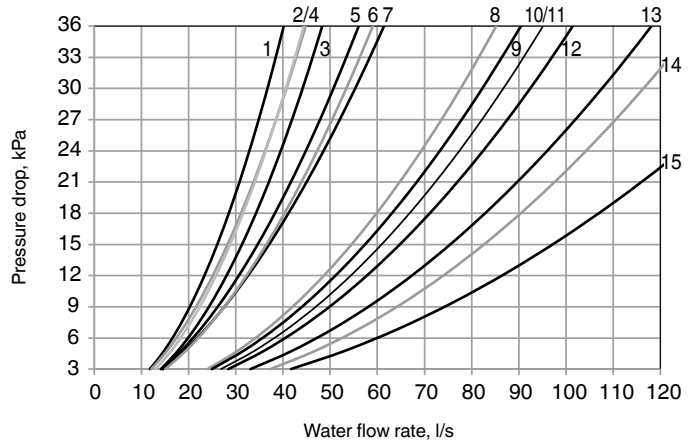

**Legend**

- 1. 254
- 2. 304
- 3. 354
- 4. 402, 452, 552, 602
- 5. 512, 562
- 6. 652, 702, 802
- 7. 852
- 8. 1002, 1052
- 9. 1012, 1162
- 10. 712, 812, 862
- 11. 1252, 1352, 1452, 1552
- 12. 1154
- 13. 1314, 1464
- 14. 1652, 1702
- 15. 1612, 1762

# Condenser pressure drop curves

**Units with two condenser passes (standard):**  
**30XW--/30XWH-/30XW-P/30XWHP**

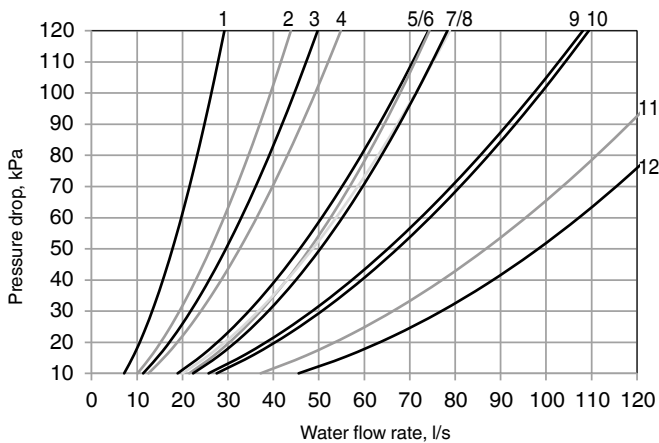

**Legend**

- 1. 254, 304, 354
- 2. 402, 452, 552, 602
- 3. 512, 562
- 4. 652, 702, 802
- 5. 712, 812, 862
- 6. 852
- 7. 1154
- 8. 1002, 1052
- 9. 1012, 1162
- 10. 1252, 1352, 1452, 1552, 1314, 1464
- 11. 1652, 1702
- 12. 1612, 1762

**Units with one condenser pass (option 102C):**  
**30XW--/30XWH-/30XW-P/30XWHP**

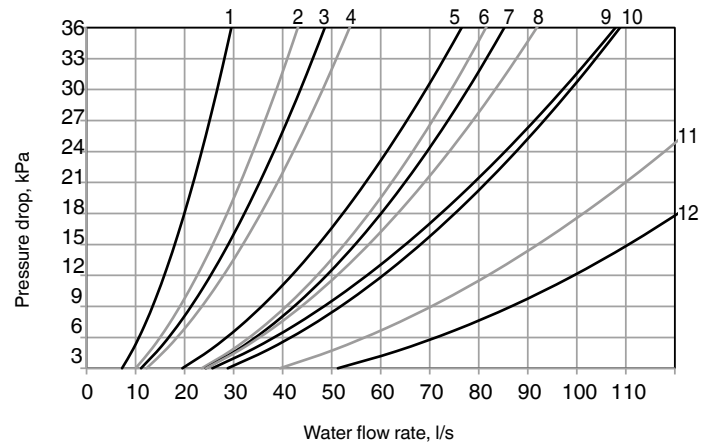

**Legend**

- 1. 254, 304, 354
- 2. 402, 452, 552, 602
- 3. 512, 562
- 4. 652, 702, 802
- 5. 712, 812, 862
- 6. 852
- 7. 1002, 1052
- 8. 1154
- 9. 1012, 1162
- 10. 1252, 1352, 1452, 1552, 1314, 1464
- 11. 1652, 1702
- 12. 1612, 1762



# Dimensions/clearances

30XW--/30XWH- 254-852  
30XW-P/30XWHP 512-862

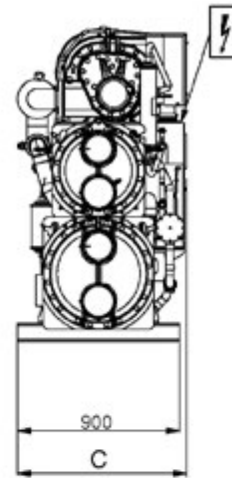
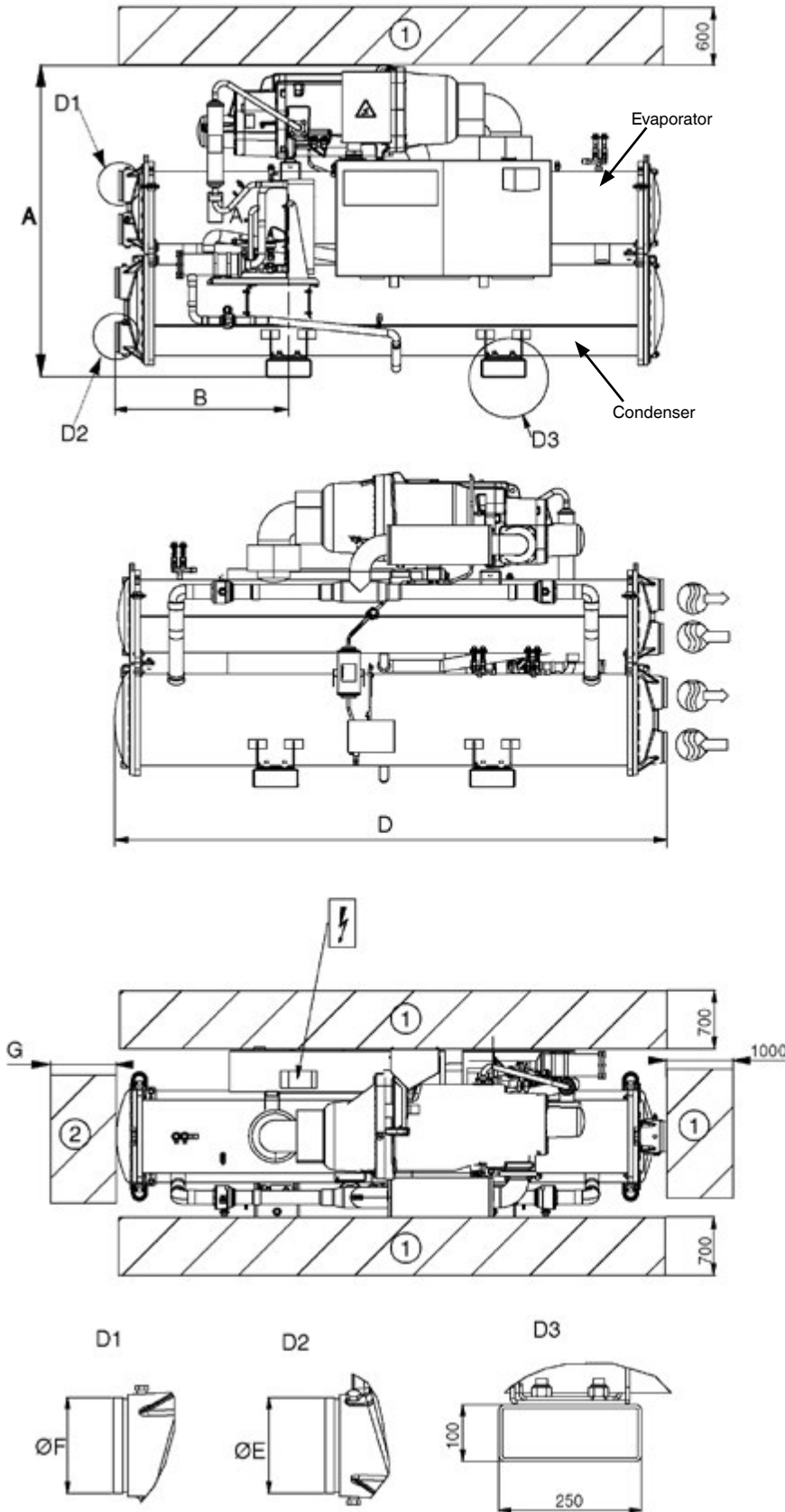

Dimensions in mm							
	A	B	C	D	E	F	G
<b>Standard-efficiency units 30XW--/30XWH-</b>							
254	1567	800	928	2724	141.3	141.3	2600
304	1567	800	928	2724	141.3	141.3	2600
354	1567	800	928	2724	141.3	141.3	2600
402	1693	810	936	2742	141.3	141.3	2600
452	1693	810	936	2742	141.3	141.3	2600
552	1693	810	936	2742	141.3	141.3	2600
602	1693	810	936	2742	141.3	141.3	2600
652	1848	968	1044	3059	168.3	168.3	2800
702	1848	968	1044	3059	168.3	168.3	2800
802	1848	968	1044	3059	168.3	168.3	2800
852	1898	828	1044	2780	219.1	168.3	2600
<b>High-efficiency units 30XW-P/30XWHP</b>							
512	1743	968	936	3059	168.3	168.3	2800
562	1743	968	936	3059	168.3	168.3	2800
712	1950	1083	1065	3290	219.1	219.1	3100
812	1950	1083	1070	3290	219.1	219.1	3100
862	1950	1083	1070	3290	219.1	219.1	3100
<b>Standard-efficiency units 30XW--/30XWH- (option 150)</b>							
254	1567	800	928	2724	141.3	141.3	2600
304	1567	800	928	2724	141.3	141.3	2600
354	1567	800	928	2724	141.3	141.3	2600
402	1693	810	936	2742	141.3	141.3	2600
452	1693	810	936	2742	141.3	141.3	2600
552	1693	810	936	2742	141.3	141.3	2600
602	1693	810	936	2742	141.3	141.3	2600
652	1868	968	1090	3059	168.3	168.3	2800
702	1868	968	1090	3059	168.3	168.3	2800
802	1868	968	1090	3059	168.3	168.3	2800
852	1920	828	1090	2780	168.3	219.1	2600
<b>High-efficiency units 30XW-P/30XWHP (option 150)</b>							
512	1743	968	936	3059	168.3	168.3	2800
562	1743	968	936	3059	168.3	168.3	2800
712	1970	1083	1105	3290	219.1	219.1	3100
812	1970	1083	1105	3290	219.1	219.1	3100
862	1970	1083	1105	3290	219.1	219.1	3100

**Legend:**

All dimensions are in mm.

- ① Required clearance for maintenance
- ② Recommended clearance for tube removal

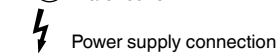

**NOTE:** Drawings are not contractually binding. Before designing an installation, consult the certified dimensional drawings, available on request.

# Specification Guide

## General description

(30XW / 30XW-P) Factory assembled single piece water-cooled chiller, shall include all factory wiring, piping, controls, refrigerant charge (HFC-134a), refrigeration circuits, screw compressors, electronic expansion valves and equipment required prior to field start-up.

(30XWH / 30XWHP) Factory assembled single piece water-sourced heat pump, shall include all factory wiring, piping, controls, refrigerant charge (HFC-134a), refrigeration circuits, screw compressors, electronic expansion valves and equipment required prior to field start-up.

## Quality assurance

Unit construction shall comply with European directives:

- Pressurized equipment directive (PED) 97/23/EC
- Machinery directive 2006/42/EC, modified
- Low voltage directive 2006/95/EC, modified
- Electromagnetic compatibility directive 2004/108/EC, modified, and the applicable recommendations of European standards
- Machine safety: electrical equipment in machines, general requirements, EN 60204-1
- Electromagnetic compatibility emission EN61000-6-4
- Electromagnetic compatibility immunity EN61000-6-2

Unit shall be designed, manufactured and tested in a facility with a quality management system certified ISO 9001 and environmental management system ISO 14001. Unit shall be run tested at the factory.

## Design performance data

- Cooling capacity (kW): .....
- Unit power input (kW): .....
- Full load energy efficiency, EER (kW/kW): .....
- Eurovent Class .....
- Part load energy efficiency, ESEER (kW/kW): .....
- Evaporator entering/leaving water temperature (°C): ... /
- Fluid type: .....
- Fluid flow rate (l/s): .....
- Evaporator pressure drops (kPa): .....
- Condenser entering/leaving water temperature (°C): .....
- Fluid type: .....
- Fluid flow rate (l/s): .....
- Condenser pressure drops (kPa): .....
- Sound power level at full load (dB(A)): .....
- Dimensions, length x depth x height (mm): ... x ... x

Performance shall be declared in accordance with EN14511-3:2013 and certified by Eurovent up to 1500 kW.

The unit shall be capable of starting with 13 °C entering water temperature to the condenser with condenser head pressure control option. The unit shall be capable of starting with 35 °C entering water temperature to the evaporator.

The machine shall operate with condenser leaving water temperature up to 50 °C.

- (*Carrier option 150*) The machine shall operate with condenser leaving water temperature up to 63 °C.
- (*Carrier option 5*) The unit shall permit chilled brine solution production down to -6 °C when ethylene glycol is used, or down to -3°C when propylene glycol is used.
- (*Carrier option 6*) The unit shall permit chilled brine solution production down to -12 °C when ethylene glycol is used, or down to -8 °C when propylene glycol is used.

## Frame

- Machine frame shall include heat exchangers and compressors in a self-supporting structure
- Electrical panel doors shall be accessible by 1/4-turn screws

## Compressor

- Unit shall have semi-hermetic twin-screw compressors with internal relief valve and check valve to avoid reverse rotation on shut down
- Each compressor shall be equipped with a discharge shut-off valve
- The discharge shall also be equipped with a muffler to reduce discharge gas pulsations
- Compressor bearings shall be designed for minimum 73000 hours at maximum operating conditions
- Capacity control shall be provided by a slide valve
- Compressor capacity control shall be stepless from 100% to 15% load
- Compressor shall start in unloaded condition
- Motor shall be cooled by suction gas and protected through a dedicated electronic board against the following: thermal overload by internal winding temperature sensors, electrical overload and short circuit by dedicated fuses (one per phase), reverse rotation, loss of phase, undervoltage and power supply failure
- Lubrication oil system shall include pre-filter and external filter capable of filtration to 5 microns
- The oil filter line shall be equipped with service shut off valves for easy filter replacement
- The oil separator, shall be integrated in the condenser design and shall not require oil pump
- The oil separator shall include an oil level safety switch.

## Evaporator

- Unit shall be equipped with a single flooded evaporator
- Evaporator shall be manufactured by the chiller manufacturer
- Evaporator shall be tested and stamped in accordance with the European directive for pressurized equipment 97/23/EC
- The maximum refrigerant-side operating pressure will be 2100 kPa, and the maximum waterside pressure will be 1000 kPa (2100kPa as an option)
- The evaporator shall be mechanically cleanable, shell-and-tube type with removable heads
- Tubes shall be internally and externally grooved, seamless-copper, and shall be rolled into tube sheets
- Shell shall be insulated with 19 mm closed-cell foam with a maximum K factor of 0.28. Evaporator thermal insulation shall be factory fitted
- The evaporator shall have a drain and vent in each head
- Chiller shall have only one water inlet & outlet connection with Victaulic couplings to avoid vibrations transmission and to accommodate minor pipework misalignment (Victaulic adapter kit shall be available on demand)
- The evaporator shall incorporate an indirect refrigerant level control system (based on the continuous measurement of the approach value) to ensure optimum heat transfer performance under all load conditions
- Design shall incorporate either 1 or 2 independent refrigerant circuits
- Evaporator shall be fitted with electronic auto setting water flow switch. Paddle switches or differential pressure switches shall not be acceptable.

## Condenser

- Unit shall be equipped with a single condenser
- Condenser shall be manufactured by the chiller manufacturer
- Condenser shall be tested and stamped in accordance with the European directive for pressurized equipment 97/23/EC
- Single pass or 2-passes design shall be possible
- The maximum refrigerant-side operating pressure will be 2100 kPa, and the maximum waterside pressure will be 1000 kPa (2100kPa as an option)
- The condenser shall be mechanically cleanable shell-and-tube type with removable heads
- Tubes shall be internally and externally grooved, seamless-copper, and shall be rolled into tube sheets
- The condenser shall have a drain and vent in each head
- Chiller shall have only one water inlet & outlet connection with Victaulic couplings to avoid vibrations transmission and to accommodate minor pipework misalignment (Victaulic adapter kit shall be available on demand)
- Design shall incorporate either 1 or 2 independent refrigerant circuits and the oil separator.

## Refrigerant circuit

- Refrigerant circuit components shall include: compressor, oil separator, high and low side pressure relief devices, economizer, filter driers, moisture indicating sight glasses, long stroke electronic expansion device, and complete operating charge of both refrigerant R134a and compressor oil
- (*Carrier option 92*) A compressor suction and discharge line shut off valve, an evaporator inlet valve and economizer line valve, shall be mounted to isolate all main components (filter drier, oil filter, expansion device and compressor) and allow refrigerant to be safely stored during service operation
- (*Carrier option 257*) Evaporator and refrigerant gas suction line shall be acoustically insulated.

## Power control box

- Unit shall operate at 400 Volts (+/- 10%), 3-phases, 50 Hertz power supply without neutral
- Unit shall be designed for simplified connection on TN(s) networks
- Control circuit voltage shall be 24 V maximum, supplied by a factory-installed transformer
- Unit shall be supplied with factory-installed main circuit breaker/isolator
- Unit shall have single point power connection (*Carrier option 81* for sizes 1002/1762)
- Unit shall have a factory installed star/delta starter as standard to limit electrical inrush current
- Power control box is powered painted with hinged and gasket sealed doors and is protected to IP23.

## Controls

- Unit control shall include as a minimum: microprocessor with non-volatile memory, picture guided unit/operator interface, the LOCAL/OFF/REMOTE/CCN selector and a 5 inches coloured touch-screen display with multiple language capability
- Pressure sensors shall be installed to measure suction, discharge, and oil pressure
- Temperature probes shall be installed to read cooler/condenser entering and leaving temperatures.

- (*Carrier option 158A*) Unit control shall include as a minimum: microprocessor with non-volatile memory, picture guided unit/operator interface, the LOCAL/OFF/REMOTE/CCN selector and a 7 inches coloured touch-screen display with multiple language capability
- Unit control shall have an IP port to permit user connection via web browser, allowing same level of access to control menus as unit mounted interface (excluding start/stop and alarm reset capabilities)
- Control shall store technical documentation, drawings and spare parts list specific to each particular unit
- (*Carrier option 148B*) A two-directional communication board shall allow plug and play interfacing of the machine with any BMS using the J-Bus protocol
- (*Carrier option 148D*) A two-directional communication board shall allow plug and play interfacing of the machine with any BMS using the LonTalk protocol
- (*Carrier option 149*) Machine shall be supplied with factory-installed two-directional high-speed communication using BACnet protocol over Ethernet network (IP-connection). The BACnet over-IP communication shall have no limitation in reading/writing controller points and shall use standardized alarm codes as defined with BACnet protocol. Filed programming shall be required.
- (*Carrier option 298*) Machine shall be accessible via wireless connection for remote monitoring with the scope of preventive maintenance.

Unit shall be capable of performing the following functions:

- Electronic expansion valve control optimizing evaporator refrigerant charge while ensuring minimum refrigerant superheat and optimum subcooling at condenser outlet
  - Capacity control based on leaving chilled fluid temperature
  - Limitation of the chilled fluid-temperature pull-down rate at start-up to an adjustable range of 0.1°C to 1.1°C per minute to prevent excessive demand spikes at start-up
  - Automatic change-over and cycling of compressors to equalize running hours and number of starts
  - Reset enable of leaving chilled-water temperature based on the outdoor air temperature or via 0-10 V signal (as option)
  - Dual set point management for the leaving chilled water temperature activated by a remote contact closure signal or by the built in time clock
  - 2-level demand limit control (between 0 and 100%) activated by remote contact closure or by the built in time clock
  - Time scheduling management to enable unit start-up control, demand limit and set-point changes
  - Trending of main variables
  - (*Carrier option 58*) lead/lag type control of two chillers running in series or parallel
  - (*Carrier option 84*) Water pump control, safety pumps (if installed) on both condenser and cooler side
  - (*Carrier option 156*) The following inputs contacts shall be available on the unit control board:
    - Setpoint reset by indoor air temperature sensor
    - Cooling setpoint reset by 4-20 mA
    - Time schedule override
    - Ice storage input
    - Demand limit
    - Unit shut down
- The following outputs contacts shall be available on the unit control board:
- Instantaneous chiller capacity by 0-10 V signal
  - Complete shut-down due to a chiller fault
  - Compressor operation indication.



Order No.13457-20, 03.2017. Supersedes order No. 13457-20, 05.2015.  
Manufacturer reserves the right to change any product specifications without notice.



Quality and Environment  
Management Systems  
Approval

Manufactured by: Carrier SCS, Montluel, France.  
Printed in the European Union.